

Specifications

Output Power HP (kW)	50 (37)
Phase	3 Phase
Pole	6 Pole
Frame Number	200L

Degrees of Protection	IP 55
Enclosure Construction	Totally-enclosed Fan-cooled
Thermal Class	Class F (155 °C)

Alignment	Horizontal
Frame Material	Cast Iron

Power Transmission	Direct-couple or Belt Driven
Direction of Rotation	Counterclockwise (CCW) viewed from shaft-end side



Connection Type	Lead Wire (6 Leads)
Coating Colour	Munsell N5.5 (Gray)
Conformed Standard	IEC 60034-1 & JEC-2137-2000



Voltage & Frequency	HT Type
	380~415V 50Hz
	380~440V 60Hz (suitable for Y-Δ starting)

* The perpendicular variation of tolerance for the shaft center is ± 0.5

Dimensions (mm)

Motor												
A	B	C*	D	E	F	G	H	J	JK	K	L	M
370.5	281	200	410	159	152.5	25	405	80	R6	78	796	390

Motor			Terminal Box				Shaft End						
N	XB	Z	KA	KG	KD	KP	Q	QK	R	S	T	U	W
369	133	18.5	120	476	PF 2	550	140	110	425.5	60 m6	11	7	18

Bearing No.		Approximated Weight (kg)	Approximated Packing Dimensions (LxWxH)	Gross Weight (kg)
Drive End	Opposite			
6313ZZ	6311ZZ	340	964 x 542 x 691	367

Connection & Connection Diagram

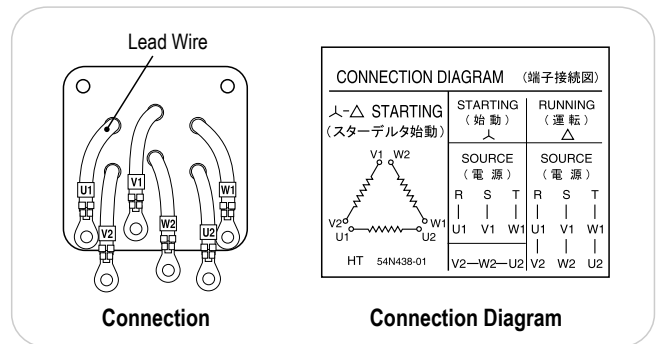

Circumstance Conditions

Ambient Temperature	-20 ~ +40°C
Ambient Humidity	95% RH or less
Operating Altitude	Less than 1,000m above sea level
Environment	No bursting / erosive gas or vapor

Motor Characteristics

Type	Hz	V	50% Load			75% Load			100% Load				Torque(%)		Is (A)	Inertia GD ² (kg-m ²)	
			(A)	Eff(%)	PF(%)	(A)	Eff(%)	PF(%)	(A)	Eff(%)	PF(%)	Speed (r/min)	Torque (kg-m)	Ts			Tm
HT	50	380	43.4	0.92	0.70	57.0	0.94	0.79	73.0	0.92	0.83	960	37.5	307	251	451	2.60
		415	49.1	0.87	0.61	60.0	0.88	0.73	73.0	0.89	0.79	970	37.2	370	296	493	
	60	380	38.2	0.92	0.80	53.1	0.92	0.86	70.0	0.91	0.88	1150	31.3	252	214	390	
		440	38.4	0.92	0.69	49.6	0.94	0.78	62.6	0.93	0.83	1170	30.8	344	288	452	